



AN ACTIVE COMB FILTER DESIGN FOR HARMONIC INTERFERENCE REMOVAL

Chang-Da Tsai, Dah-Chuan Chiou, Yue-Der Lin, Hsiao-Lung Chan, and Chien-Ping Wu*
*Department of Electrical Engineering
National Taiwan University
Taipei, Taiwan 106, R.O.C.*

Key Words : harmonic interference, active comb filter.

ABSTRACT

The active comb filter without the use of inductors is very useful for removing harmonic noise such as power line interference in biomedical signals. This paper presents an approach for the design of an active comb filter. A table composed of 62 bandpass filters is proposed, which can be used in the design of the presented active comb filter. Simulation results and performance tests are given to demonstrate the feasibility of the presented active comb filter.

I. INTRODUCTION

A major problem in the recording of biomedical signals is that the measurement signals are usually contaminated by power line (AC) interferences [5, 8]. These interferences can disrupt interpretation of low-amplitude biomedical signals. Usually, there are two components in AC interferences. One is electrical field interference characterized by noise concentrated at the fundamental frequency. The other is magnetic field interference which is derived from transformers in the power supply and is characterized by high harmonic contents. These harmonics are due to the nonlinear characteristics of transformer cores. The elimination of higher frequency harmonics is seldom considered because the major components of physiological signals are concentrated at low frequencies, and the higher frequency harmonic interference has less magnitude than the fundamental frequency interference. However, information from high frequency contents for some electrophysiological signals, such as the high-resolution electrocardiogram (ECG), is just as important in physiology and pathology as information from low frequency contents [13]. Thus, to design a comb filter that can

reduce AC interferences becomes an important subject for many biomedical applications.

The elimination of AC interferences in physiological signals can be accomplished by digital filters [1-3, 7, 9, 11-12, 14]. However, active analog filters without the use of inductors cost less and are more suitable for real-time processing than digital filters. It is worthwhile to develop an active comb filter for various applications of harmonics elimination. The presented active comb filter requires some bandpass filters to extract harmonic interferences in the input signal. A table composed of 62 bandpass filters derived from a general form of multiple-feedback filter structure is given, to provide design flexibility of the presented active comb filter.

The paper is organized as follows. In section II, the approach of an active comb filter is described and a table composed of 62 bandpass filters is proposed. Section III presents the simulation and experimental results of the presented active comb filter. Finally, conclusions are made in section IV.

II. ACTIVE COMB FILTER DESIGN

In this paper, we consider the following

*Correspondence addressee

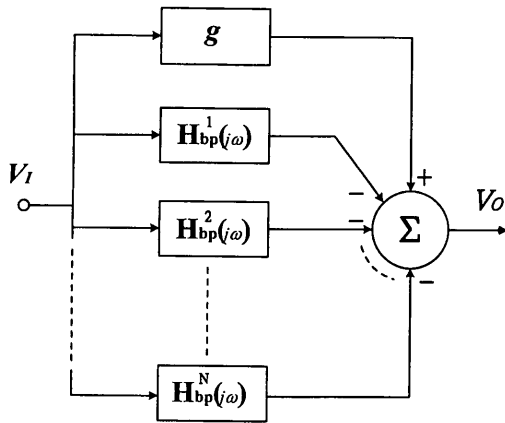

Fig. 1. Structure to realize active comb filter. Note that $H_{bp}^k(j\omega)$ is a bandpass filter with negative gain of g .

measured signal $V_i(t)$:

$$V_i(t) = S(t) + \sum_{k=1}^N A_k \sin(k\omega_o t + \phi_k) = S(t) + I(t) \tag{1}$$

where $S(t)$ is the desired signal and $I(t)$ is the harmonic interference. The fundamental frequency f_o ($\omega_o = 2\pi f_o$) is usually 50 Hz or 60 Hz. Given the noisy signal $V_i(t)$, the objective of this study was to retrieve the signal $S(t)$ from $V_i(t)$ by using the comb filtering technique.

Based on the signal described as Eq. (1), the specification of an ideal active comb filter is given by

$$H(j\omega) = \begin{cases} 0, & \omega = k\omega_o, k = 1, 2, \dots, N \\ g, & \text{otherwise} \end{cases} \tag{2}$$

where g is the passband gain.

The block diagram to approach a comb filter is shown in Fig.1. Its transfer function $H(j\omega)$ is given by

$$H(j\omega) = g[1 - \sum_{k=1}^N H_{bp}^k(j\omega)] \tag{3}$$

where $H_{bp}^k(j\omega)$ is a bandpass filter with resonant gain p , and zero phase at resonant frequency $k\omega_o$. The function of bandpass filter $H_{bp}^k(j\omega)$ is used to extract the k th harmonic component $A_k \sin(k\omega_o t + \phi_k)$ from input signal $V_i(t)$ with a minimal amount of distortion. To subtract the sum of each extracted component from the input signal is equivalent to eliminating the harmonic interferences added in $V_i(t)$. Thus, $H(j\omega)$ is a desired active comb filter.

An analog approach to designing a comb filter is shown in Fig. 2. Several negative-gain bandpass filters (NBFs) are used to extract the harmonic

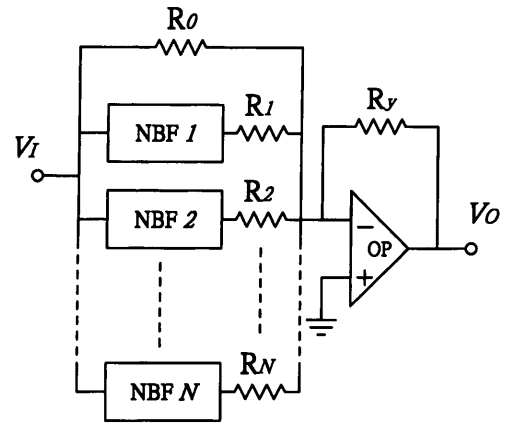

Fig. 2. An analog approach to designing an active comb filter. NBF: negative-gain bandpass filter.

interferences from input signal $V_i(t)$ with the constraint

$$\frac{R_y}{R_0} = \frac{PR_y}{R_k} = g, \tag{4}$$

and $k=1, 2, \dots, N$.

Therefore, the issue of how to design an active comb filter is equal to that of how to design the NBFs. In addition to the resonant frequency, the quality factor is another important parameter in the design of bandpass filters. Higher quality factor design of the NBFs makes the presented circuit closer to an ideal active comb filter, but more sensitive to its components. On the other hand, lower quality factor design of the NBFs will result in a broader band band-rejection feature.

A filter bank composed of various narrow-band bandpass filters (high quality factor design) and broad-band bandpass filters (low quality factor design) is provided for various applications. Fig. 3 is a general structure of a multiple-feedback filter that is used to build up the bandpass filter bank. The structure comprises an operational amplifier and five passive elements symbolically. Assuming that the operational amplifier is ideal, the transfer function of the multiple-feedback filter can be derived as

$$\frac{V_0}{V_i} = \frac{-Y_1 Y_4}{Y_2 Y_4 + Y_5(Y_1 + Y_2 + Y_3 + Y_4)} \tag{5}$$

where Y_k is the admittance of the k th element, and $1 \leq k \leq 5$.

The multiple-feedback filter can be synthesized with capacitors and resistors to perform as various bandpass filters with a large spread of quality factor from Eq. (5). The syntheses of 62 bandpass filters are listed in Table 1. Table 1 contains narrow-band bandpass filters as well as broad-band bandpass

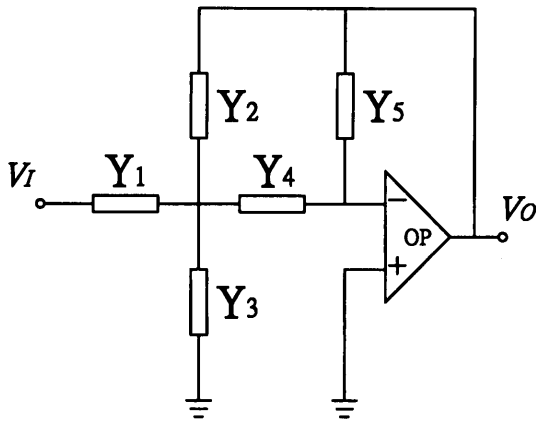

Fig.3. A general form of a multiple-feedback filter.

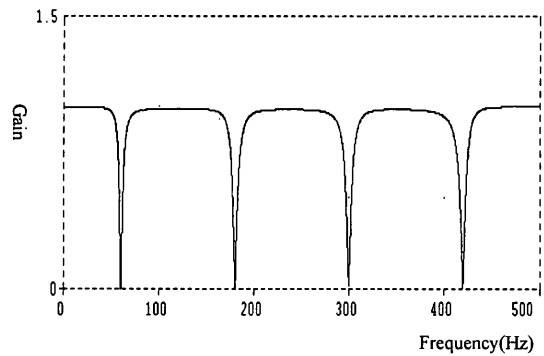

Fig. 4. Spice simulation of the presented active comb filter with $N=4$. The resonant frequencies and the quality factors of the bandpass filters are in the order of 60, 180, 300, 420 Hz and 10, 20, 30, 40, respectively.

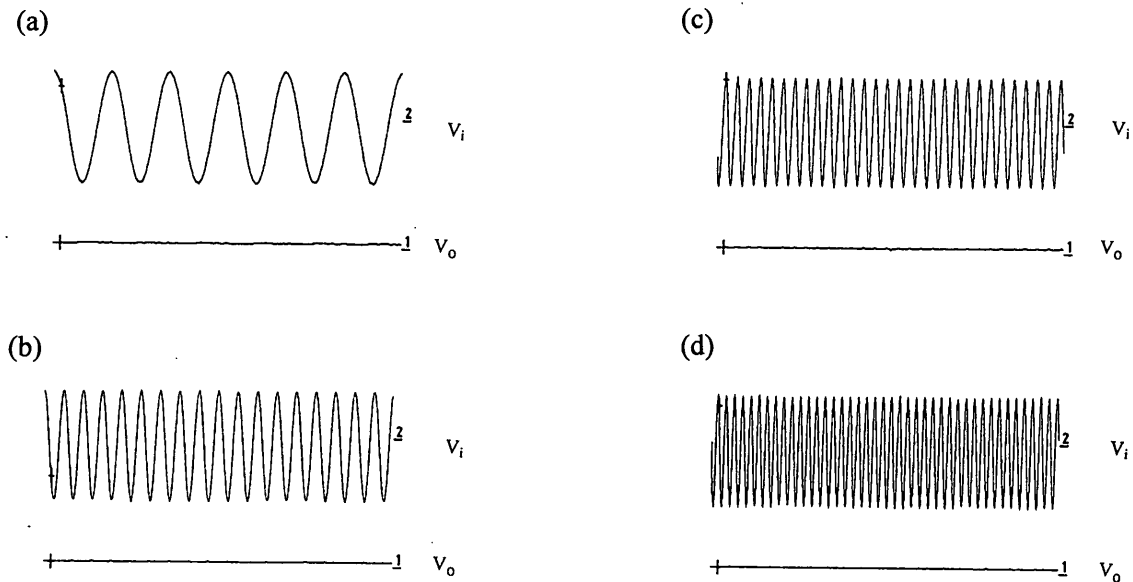

Fig. 5. Experimental results of sinusoidal wave test: (a) 60 Hz (b) 180 Hz (c) 300 Hz (d) 420 Hz.

filters for various applications depending on the measured signal and the spectral energy distribution of the ambient interference. The symbol of 'C' is capacitance and that of 'A' is admittance of the resistor. ' A_k ' and ' C_k ' are, respectively, conductance and capacitance of the k th element. '0' indicates the admittance is zero, and '&' indicates the admittance is infinite. Note that number 59 is a popular circuit which can often be found in textbooks and the literature. The design procedure as well as the sensitivity analysis of this circuit is provided in detail in [4, 6, 10, 15, 16]. Thus, we chose circuit number 59 to realize the presented active comb filter for the experimental test.

III. RESULTS

In order to illustrate the effectiveness of the

analog approach, a Spice simulation was performed to demonstrate the performance of the presented active comb filter with $N=4$. All the bandpass filters of the comb filter are realized with circuit number 59 of Table 1. The resonant frequencies and the quality factors of the bandpass filters were, respectively, in the order of 60, 180, 300, 420 Hz (odd harmonics) and 10, 20, 30, 40. As shown in Fig. 4, the simulation results verified the presented analog approach as an excellent comb filter.

To further demonstrate the feasibility of the active comb filter, the circuit was realized with the same configuration as that in the simulation, and tested with sinusoidal and triangular waves. Firstly, four harmonic frequencies of sinusoidal wave (60, 180, 300, and 420 Hz) were fed to the active comb filter. The resultant output waveforms are shown in Fig. 5. It is clear that all of the four sinusoidal waves can be

Table 1. Syntheses of bandpass filters.

| | Y ₁ | Y ₂ | Y ₃ | Y ₄ | Y ₅ | Transfer Function |
|----|----------------|----------------|----------------|----------------|----------------|--|
| 1 | A | 0 | 0 | CS | A+CS | $-C_4A_1S/(C_4A_5)S^2+(C_4A_5+A_1C_5)S+(A_1A_5)$ |
| 2 | A | CS | 0 | CS | A | $-C_4A_1S/(C_4A_2)S^2+(C_2A_5+C_4C_5)S+(A_1A_5)$ |
| 3 | CS | 0 | 0 | A | A+CS | $-A_4C_1S/(C_1C_5)S^2+(C_1A_5+A_4C_5)S+(A_4A_5)$ |
| 4 | CS | A | 0 | A | CS | $-A_4C_1S/(C_1C_5)S^2+(A_2C_5+A_4C_5)S+(A_4A_2)$ |
| 5 | A//CS | A+CS | 0 | & | 0 | $-A_1C_1S/(C_1C_2)S^2+(C_1A_2+A_1C_2)S+(A_1A_2)$ |
| 6 | A//CS | A+CS | & | & | 0 | $-A_1C_1S/(C_1C_2)S^2+(C_1A_2+A_1C_2)S+(A_1A_2)$ |
| 7 | A//CS | A+CS | A | & | 0 | $-A_1C_1S/(C_1C_2)S^2+(C_1A_2+A_1C_2)S+(A_1A_2)$ |
| 8 | A//CS | A+CS | CS | & | 0 | $-A_1C_1S/(C_1C_2)S^2+(C_1A_2+A_1C_2)S+(A_1A_2)$ |
| 9 | A//CS | A+CS | A+CS | & | 0 | $-A_1C_1S/(C_1C_2)S^2+(C_1A_2+A_1C_2)S+(A_1A_2)$ |
| 10 | A//CS | 0 | A+CS | & | A+CS | $-A_1C_1S/(C_1C_5)S^2+(C_1A_5+A_1C_2)S+(A_1A_5)$ |
| 11 | A//CS | A+CS | A//CS | & | 0 | $-A_1C_1S/(C_1C_2)S^2+(C_1A_2+A_1C_2)S+(A_1A_2)$ |
| 12 | A//CS | CS | 0 | & | A | $-A_1C_1S/(C_1C_2)S^2+(C_1A_5+A_1C_2)S+(A_1A_5)$ |
| 13 | A//CS | CS | & | & | A | $-A_1C_1S/(C_1C_2)S^2+(C_1A_5+C_1C_2)S+(A_1A_5)$ |
| 14 | A//CS | CS | A | & | A | $-A_1C_1S/(C_1C_2)S^2+(C_1A_5+A_1C_2)S+(A_1A_5)$ |
| 15 | A//CS | 0 | A//CS | & | A+CS | $-A_1C_1S/(C_1C_5)S^2+(C_1A_5+A_1C_5)S+(A_1A_5)$ |
| 16 | A//CS | CS | CS | & | A | $-A_1C_1S/(C_1C_2)S^2+(C_1A_5+A_1C_2)S+(A_1A_5)$ |
| 17 | A//CS | CS | A+CS | & | A | $-A_1C_1S/(C_1C_2)S^2+(C_1A_5+A_1C_2)S+(A_1A_5)$ |
| 18 | A//CS | CS | A//CS | & | A | $-A_1C_1S/(C_1C_2)S^2+(C_1A_5+A_1C_2)S+(A_1A_5)$ |
| 19 | A//CS | A | & | & | CS | $-A_1C_1S/(C_1C_5)S^2+(A_1C_5+C_1A_2)S+(A_1A_2)$ |
| 20 | A//CS | A | A | & | CS | $-A_1C_1S/(C_1C_5)S^2+(A_1C_5+C_1A_2)S+(A_1A_2)$ |
| 21 | A//CS | A | CS | & | CS | $-A_1C_1S/(C_1C_5)S^2+(A_1C_5+C_1A_2)S+(A_1A_2)$ |
| 22 | A//CS | A | A+CS | & | CS | $-A_1C_1S/(C_1C_5)S^2+(A_1C_5+C_1A_2)S+(A_1A_2)$ |
| 23 | A//CS | A | A//CS | & | CS | $-A_1C_1S/(C_1C_5)S^2+(A_1C_5+C_1A_2)S+(A_1A_2)$ |
| 24 | A//CS | 0 | A | & | A+CS | $-A_1C_1S/(C_1C_5)S^2+(C_1A_5+A_1C_5)S+(A_1A_5)$ |
| 25 | A//CS | 0 | 0 | & | A+CS | $-A_1C_1S/(C_1C_5)S^2+(C_1A_5+C_1C_5)S+(A_1A_5)$ |
| 26 | A//CS | 0 | & | & | A+CS | $-A_1C_1S/(C_1C_5)S^2+(C_1A_5+A_1C_5)S+(A_1A_5)$ |
| 27 | A//CS | A | 0 | & | CS | $-A_1C_1S/(C_1C_5)S^2+(A_2C_5+C_1A_2)S+(A_1A_2)$ |
| 28 | A//CS | 0 | CS | & | A+CS | $-A_1C_1S/(C_1C_5)S^2+(C_1A_5+A_1C_5)S+(A_1A_5)$ |
| 29 | & | 0 | 0 | A//CS | A+CS | $-A_4C_4S/(C_4A_5)S^2+(C_4A_5+C_4C_5)S+(A_4A_5)$ |
| 30 | & | A | 0 | A//CS | A+CS | $-A_4C_4S/(C_4C_5)S^2+(C_4A_5+A_4C_5)S+(A_4A_5)$ |
| 31 | & | CS | 0 | A//CS | A+CS | $-A_4C_4S/(C_4C_5)S^2+(C_4A_5+A_4C_5)S+(A_4A_5)$ |
| 32 | & | A+CS | 0 | A//CS | A+CS | $-A_4A_4S/(C_4C_5)S^2+(C_4A_5+A_4C_5)S+(A_4A_5)$ |
| 33 | & | A//CS | 0 | A//CS | A+CS | $-A_4A_4S/(C_4C_5)S^2+(C_4A_5+A_4C_5)S+(A_4A_5)$ |
| 34 | & | 0 | & | A//CS | A+CS | $-A_4C_4S/(C_4C_5)S^2+(C_4A_5+A_4C_5)S+(A_4A_5)$ |
| 35 | & | A | & | A//CS | A+CS | $-A_4C_4S/(C_4C_5)S^2+(C_4A_5+A_4C_5)S+(A_4A_5)$ |
| 36 | & | CS | & | A//CS | A+CS | $-A_4C_4S/(C_4C_5)S^2+(C_4A_5+A_4C_5)S+(A_4A_5)$ |
| 37 | & | A+CS | & | A//CS | A+CS | $-A_4C_4S/(C_4C_5)S^2+(C_4A_5+A_4C_5)S+(A_4A_5)$ |
| 38 | & | A// | & | A//CS | A+CS | $-A_4C_4S/(C_4C_5)S^2+(C_4A_5+A_4C_5)S+(A_4A_5)$ |
| 39 | & | 0 | 0 | A//CS | A+CS | $-A_4C_4S/(C_4C_5)S^2+(C_4A_5+A_4C_5)S+(A_4A_5)$ |
| 40 | & | A | A | A//CS | A+CS | $-A_4C_4S/(C_4C_5)S^2+(C_4A_5+A_4C_5)S+(A_4A_5)$ |
| 41 | & | CS | A | A//CS | A+CS | $-A_4C_4S/(C_4C_5)S^2+(C_4A_5+A_4C_5)S+(A_4A_5)$ |
| 42 | & | A+CS | A | A//CS | A+CS | $-A_4C_4S/(C_4C_5)S^2+(C_4A_5+A_4C_5)S+(A_4A_5)$ |
| 43 | & | A//CS | A | A//CS | A+CS | $-A_4C_4S/(C_4C_2)S^2+(C_4A_5+A_4C_5)S+(A_4A_5)$ |
| 44 | & | 0 | CS | A//CS | A+CS | $-A_4C_4S/(C_4C_5)S^2+(C_4A_5+A_4C_5)S+(A_4A_5)$ |
| 45 | & | A | CS | A//CS | A+CS | $-A_4C_4S/(C_4C_5)S^2+(C_4A_5+A_4C_5)S+(A_4A_5)$ |
| 46 | & | CS | CS | A//CS | A+CS | $-A_4C_4S/(C_4C_5)S^2+(C_4A_5+A_4C_5)S+(A_4A_5)$ |
| 47 | & | A+CS | CS | A//CS | A+CS | $-A_4C_4S/(C_4C_5)S^2+(C_4A_5+A_4C_5)S+(A_4A_5)$ |
| 48 | & | A//CS | CS | A//CS | A+CS | $-A_4C_4S/(C_4A_5)S^2+(C_4A_5+A_4C_5)S+(A_4A_5)$ |
| 49 | & | 0 | A+CS | A//CS | A+CS | $-A_4A_4S/(C_4C_5)S^2+(C_4A_5+A_4C_5)S+(A_4A_5)$ |
| 50 | & | A | A+CS | A//CS | A+CS | $-A_4C_4S/(C_4C_5)S^2+(C_4A_5+A_4C_5)S+(A_4A_5)$ |
| 51 | & | CS | A+CS | A//CS | A+CS | $-A_4A_4S/(C_4C_5)S^2+(C_4A_5+A_4C_5)S+(A_4A_5)$ |
| 52 | & | A+CS | A+CS | A//CS | A+CS | $-A_4C_4S/(C_4C_5)S^2+(C_4A_5+A_4C_5)S+(A_4A_5)$ |
| 53 | & | A//CS | A+CS | A//CS | A+CS | $-A_4A_4S/(C_4C_5)S^2+(C_4A_5+A_4C_5)S+(A_4A_5)$ |

| | | | | | | |
|----|----|-------|-------|-------|------|---|
| 54 | & | 0 | A//CS | A//CS | A+CS | $-A_4C_4S/(C_4C_5)S^2+(C_4A_5+A_4C_5)S+(A_4A_5)$ |
| 55 | & | A | A//CS | A//CS | A+CS | $-A_4C_4S/(C_4C_5)S^2+(C_4A_5+A_4C_5)S+(A_4A_5)$ |
| 56 | & | CS | A//CS | A//CS | A+CS | $-A_4C_4S/(C_4C_5)S^2+(C_4A_5+A_4C_5)S+(A_4A_5)$ |
| 57 | & | A+CS | A//CS | A//CS | A+CS | $-A_4C_4S/(C_4C_5)S^2+(C_4A_5+A_4C_5)S+(A_4A_5)$ |
| 58 | & | A//CS | A//CS | A//CS | A+CS | $-A_4C_4S/(C_4A_5)S^2+(C_4A_5+A_4C_5)S+(A_4A_5)$ |
| 59 | A | CS | A | CS | A | $-C_4A_1S/(C_4C_2)S^2+(C_2A_5+C_4C_5)S+(A_1A_5+A_3A_5)$ |
| 60 | A | CS | CS | CS | A | $-C_4A_1S/(C_4A_2)S^2+(C_2A_5+C_3A_5+C_4A_5)S+(A_1A_5)$ |
| 61 | CS | A | CS | A | CS | $-A_4C_1S/(C_1C_5+C_3C_5)S^2+(A_2C_5+A_4C_5)S+(A_4A_2)$ |
| 62 | CS | A | A | A | S | $-A_4C_1S/(C_1C_5)S^2+(A_2C_5+A_3C_5+A_4C_5)S+(A_4A_2)$ |

'A' is the admittance of the resistor and 'C' is capacitance.

'A_k' and 'C_k' are the conductance and the capacitance of the kth element, respectively.

'0' and '&' indicate the admittance are zero and infinite, respectively.

$$A//CS = \frac{ACS}{A + CS}$$

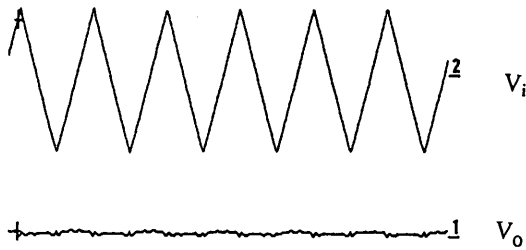

Fig. 6. Experimental results of 60 Hz triangular wave test.

significantly removed by the active comb filter. Secondly, a triangular wave of 60Hz was fed to the tested circuit. Based on Fourier series theory, the triangular wave consists of odd harmonics of the fundamental frequency. The resultant output waveforms are depicted in Fig. 6. It is obvious that most power of the triangular wave is removed by the active comb filter.

IV. CONCLUSION

An active comb filter structure as well as 62 bandpass filters which provided a large spread of quality factors for harmonic interference removal was presented. The presented active comb filter composed of some independent bandpass filters and a summing amplifier makes it versatile for various applications. The experimental tests of sinusoidal and triangular waves verified that the presented active comb filter has good performance in harmonic interference elimination.

NOMENCLATURE

| | |
|---------------------|---|
| $H(j\omega)$ | transfer function of active comb filter |
| $H_{bp}^k(j\omega)$ | transfer function of bandpass filter |
| g | passband gain of active comb filter |
| p | resonant gain of bandpass filter |
| $I(t)$ | harmonic interference |

$S(t)$ desired signal
 $V_i(t)$ noisy measured signal

Greek Symbols

ω_0, f_0 fundamental frequency of harmonics

REFERENCES

- Ahlstrom M. L., and W. J. Tompkins, "Digital Filters for Real-time ECG Signal Processing Using Microprocessors," *IEEE Transactions on Biomedical Engineering*, Vol. BME-32, pp. 708-713, (1985).
- Barr R. E. and E. K. Y. Chan, "Design and Implementation of Digital Filters for Biomedical Signal Processing," *Journal of Electrophysiology Technology*, Vol. 13, pp. 73-83, (1986).
- Ferdjallah M., and R. E. Barr, "Adaptive Digital Notch Filter Design on the Unit Circle for the Removal of Powerline Noise from Biomedical Signals," *IEEE Transactions on Biomedical Engineering*, Vol. 42, pp. 529-536, (1994).
- Franco S., Design with Operational Amplifiers and Analog Integrated Circuits, McGraw-Hill, New York, (1988).
- Huhta J. C. and J.G.Webster, "60-Hz Interference in Electrocardiograph," *IEEE Transactions on Biomedical Engineering*, Vol. BME-20, pp. 91-101, (1973).
- Hilburn J. L. and D. E. Johnson, Manual of Active Filter Design, McGraw-Hill, New York, N.Y., (1973).
- Lander P., E. J. Berbari, and R. Lazzara, "Optimal Filtering and Quality Control of the Signal-averaged ECG. High-fidelity 1-minute Recordings," *Circulation*, Vol. 91, pp. 1495-1505, (1995).
- McManus C. D., D.Neubert, and E.Cramer, "Characterization and Elimination of AC Noise

- in Electrocardiograms: A Comparison of Digital Filtering Methods," *Computers and Biomedical Research*, pp. 48-67, (1993).
9. Nehorai A. and B. Porat, "Adaptive Comb Filtering for Harmonic Signal Enhancement," *IEEE Transactions on Acoustic Speech and Signal processing*, Vol. ASSP-34, pp.1124-1138, (1986).
 10. Natarajan S. , Theory and Design of Linear Active Networks, McGraw-Hill, New York, N.Y., (1989).
 11. Parsa V., and P. A. Parker, "Multireference Adaptive Noise Cancellation Applied to Somatosensory Evoked Potentials," *IEEE Transactions on Biomedical Engineering*, Vol. 41, pp. 792-800, (1994).
 12. Pei S. C. , and C.C.Tseng, "Elimination of AC Interference in Electrocardiogram Using IIR Notch Filter with Transient Suppression," *IEEE Transactions on Biomedical Engineering*, Vol. 42, pp. 1128-1132, (1995).
 13. Reinhardt L., M. Makijarvi, T. Fetsch, J. Montonen, G. Sierra, A. Martinez-Rubio, T. Katila, M. Borggreffe and G. Breithardt, "Predictive Value of Wavelet Correlation Function of Signal-averaged Electrocardiogram in Patients after Anterior Versus Inferior Myocardial Infarction," *Journal of American College Cardiology*, Vol.27, pp.53-59, (1996).
 14. Thakor N. V. , "Adaptive Filtering of Evoked Potentials," *IEEE Transactions on Biomedical Engineering*, Vol. BME-34, pp. 6-12, (1987).
 15. Tsai C. T. , H. L. Chan, C. C. Tseng, and C. P. Wu, "Harmonic Interference Elimination by An Active Comb filter," *Proc. of IEEE Engineering in Medicine and Biology Society*, Baltimore, Maryland, pp. 964-965, (1994).
 16. William A. B. and F. J. Taylor, *Electronic Filter Design Handbook*, Third Edition, McGraw-Hill, New York, N.Y., (1995).
- Discussions of this paper may appear in the discussion section of a future issue. All discussions should be submitted to the Editor-in-Chief.
- Manuscript Received: June 17, 1997**
Revision Received: Apr. 12, 1998
and Accepted: June. 25, 1998

具有諧波干擾消除功能之主動梳型濾波器

蔡長達 邱大川 林育德 詹曉龍 吳建平*

台灣大學電機系

摘 要

主動梳型濾波器由於不須使用電感來設計電路，因此對於消除諸如伴隨微弱生醫信號之電源諧波干擾相當有用。本研究提出一種主動梳型濾波器的電路實現方法，一個包含62種帶通濾波器的表格亦呈現於文中以為主動梳型濾波器設計所選擇參考，模擬結果與實驗測試皆證明本文所提出之主動梳型濾波器確實可行。

關鍵詞：主動梳型濾波器、諧波干擾。